



**PRESSURE SWITCHES  
PRESSURE DIFFERENCE SWITCHES  
VACUUM SWITCHES**  
From 1.5 mbar to 600 bar

# DN/DA Pressure Switches

## INSTALLATION AND OPERATING INSTRUCTIONS



### Kaustubha Udyog (Orion Instruments)

S. No. 36/1/1, Sinhgad Road, Vadgaon Khurd, Pune 411 041 INDIA  
Tel.: +91-(0) 20-24393577  
Telefax : +91-(0) 20-24393577 / 25460486  
Email : ku.pressure@gmail.com

Certificate No.: FM72815



Website : [www.orion-instruments.io](http://www.orion-instruments.io)

# INSTALLATION AND OPERATING INSTRUCTIONS FOR DN/DA MODELS

## CONSTRUCTION:

The pressure switch is housed in a diecast aluminium enclosure which conforms to IP65 protection factor. The pressure capsule, at the bottom of the switch, comprises a pressure housing (either of aluminium or brass), a piston with O ring seal, surge suppressor and surge reducer. The electrical changeover is through a snap action microswitch. The electrical wiring terminates at a terminal strip to DIN43650.

## PRINCIPLE OF OPERATION:

The pressure in the pressure capsule is converted into force by means of a piston, which is balanced by a compression spring from above. When the force generated by the pressure in the pressure capsule exceeds/falls beyond the balancing spring force, an electrical element is actuated.

## MOUNTING: Please refer Fig. 1

The DN/DA series pressure switches can be mounted in any direction either on a panel or any rigid arrangement.

- Pressure switches can be mounted directly in case the mounting is rigid.
  - For panel mounting, use M5 bolts of appropriate length through the mounting holes. If the equipment is subject to vibration, please use rubber washers/pads between the panel and the switch.
  - The switch can also be secured to the panel by means of the mounting nut if the panel has the proper hole displayed in the installation drawing alongside.
- 2) Connect the pressure tubing to the pressure port. The pressure port size is generally 1/4" BSP Female, unless specifically ordered otherwise. Other sizes can be obtained via adaptors.

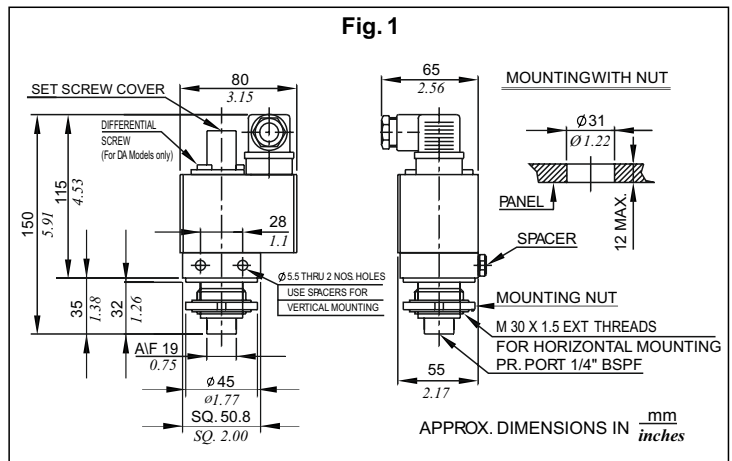

## ELECTRICAL CONNECTIONS:

DN/DA series pressure switches will generally have only one SPDT microswitch.

## WIRING: Please refer Fig.3

Connectors to DIN43650 are provided with every DN/DA model pressure switch.

- Remove the screw retaining the cap and wiring module.
- Remove the cap and wiring module.
- The cap will have to be separated from the wiring module. The wiring terminations are embossed on the wiring module. Pass the cable through the cable gland and fit the wires in the screwed ends.
- Replace the cap on to the module, depending on the direction of the cable desired and fit the module on to the base of the terminal. Fit the retaining screw on to the cap.

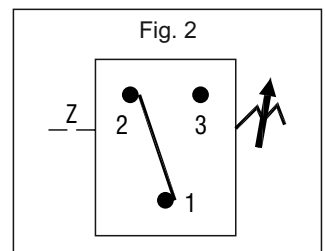

## SETPOINT ADJUSTMENT:

A) FOR DN MODELS: Please refer fig. 3

- 1) Remove the setscrew cover.
- 2) i) For DN uncalibrated Models: Turn the setscrew to the extreme negative end.  
ii) For DN calibrated Models: Adjust the desired setpoint on the scale.
- 3) Apply the desired cut-in (lower)/cutout (higher) pressure to the pressure switch.
- 4) i) For DN uncalibrated Models: Increase the pressure setting by turning the setscrew till contacts changeover.  
ii) For DN calibrated Models: Proceed to Step 5
- 5) Some minor adjustment will be required to achieve the exact cutin (lower)/cutout (higher) point, which can be checked with the help of a proper pressure measurement device.
- 6) Replace the setscrew cover.

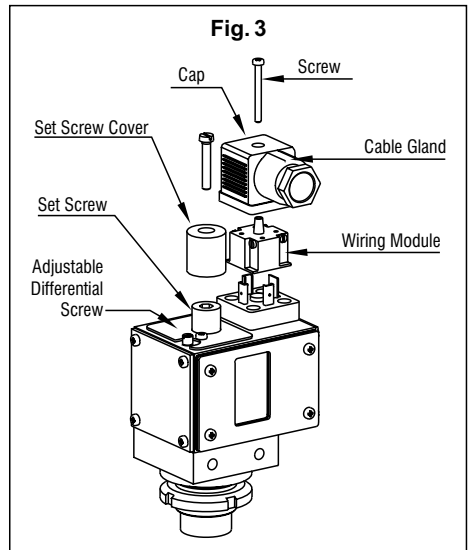

Tip.: The pressure switches are factory set at half the setpoint range (unless otherwise specified in a Purchase Order). Step 2 can be omitted if the desired setpoint is more than the factory setting.

## SETPOINT ADJUSTMENT FOR DA MODELS

- 1) Decide the cut-in (lower) pressure P1 & the cut-out (upper) pressure P2. The differential will be (P2-P1).
- 2) Remove the setscrew cover (1).
- 3) a) For DA uncalibrated models
  - i) Turn the setscrew (2) to the extreme negative end.
  - ii) Turn the differential screw (3) to the extreme negative end.
  - iii) Apply the desired cutin (lower) pressure to the pressure switch.
  - iv) Increase the pressure setting by turning the setscrew till contacts changeover.
- b) For DA calibrated models
  - i) set the cut-in point on the main-scale with the help of the set-screw.
- 4) Turn the differential screw (3) to the extreme positive end.
- 5) Apply the desired cutout (higher) pressure to the pressure switch.
- 6) Decrease the differential pressure setting by turning the differential screw (3) till contacts changeover.
- 7) Some minor adjustment will be required to achieve the exact cutin (lower)/cutout (higher) point, which can be checked with the help of proper pressure measurement device.
- 8) Replace the setscrew cover (1).

## TROUBLE SHOOTING TIPS

Generally no problems are observed if the pressure switch selection, wiring and the setpoint is proper. For a pressure switch selection procedure, please consult our sales office. For properly selected pressure switches, if following symptoms are observed, the likely causes and remedies are as stated below.

### Symptom 1: Switch does not operate

- 1) Wiring may not be correct. Check electrical connections to the pressure switch, if they are as per the wiring diagram.
- 2) Pressure does not reach the pressure port.
  - a) Check if the entry to the pressure capsule is not blocked by frozen processor scales or impurities in the process.
    - i) If this is the case, remove the surge suppressor and surge reducer, clean them with a proper solution and refit carefully into the pressure housing.
    - ii) For frozen process, it is advisable to use chemical seals.

**DO NOT OPEN THE PRESSURE CAPSULE IN ANY EVENT.**

If the cause is none of the above mentioned probabilities, proceed as per the following steps.

- b) Check the system pressure & setpoint of pressure switch. For use of pressure switch for falling setpoints, system pressure has to be greater than the cutout point.

For use of pressure switch for rising setpoints, the system pressure may not be reaching/exceeding the cutout point.

- i) For DA models turn the differential screw to the extreme negative end.
- ii) Use 'T' connection & connect calibrated pressure gauge to the 'T' connection as shown in the figure.
- iii) Adjust the setpoints such that the system pressure is greater than the cut-out point of the pressure switch.
- iv) If the switch still does not operate, remove the pressure switch physically from the system. There should be continuity between terminals 1 & 2. If no continuity is observed, the pressure switch should be returned to the factory.

### SYMPTOM 2: SHORT WIRING:

Isolate the switch electrically. Check the continuity between terminals and the screws fitted to the body. If no continuity is observed between any of the terminals and the screws fitted to the body, check the short connection elsewhere in the circuit. If continuity is observed, the wires of the pressure switch have internally touched the body, and the switch should be returned to the factory.

### SYMPTOM 3: LEAKAGE:

In case leakage is observed, the pressure switch has to be returned to the factory without opening the pressure capsule. Check for the following likely causes and use a new switch taking proper precautions.

- a) System pressure is greater than working pressure. Use an overrange protector or a switch with appropriate maximum working pressure.
- b) Incompatible wetted parts: The working medium may not be compatible with wetted parts, which damages the sealing of the process from working parts. Use a chemical seal for the pressure switch or use proper compatible wetted parts.
- c) Excessive process temperature: Process temperature may exceed maximum allowable temperature, which in turn damages the seals. Use an impulse tubing of proper length for cooling the process temperature. There may be a pressure drop depending on the length of the impulse tube used. Adjust the setpoint of the pressure switch accordingly.

### SYMPTOM 4: CHATTERING:

- 1) Check the system pressure for surges. Chattering is observed where the system pressure is close to the cutin/cutout point and the surge pressure exceeds the on-off differential. Use a pressure switch with adjustable differential or use surge dampers in your system. ■

